



**410-18 Series**  
Narrow Hole  
Pattern  
Diagonal Hub  
for Typical  
120 Series  
Applications



**410-25 Series**  
Wide Hole  
Pattern  
Vertical Hub  
for Other  
Applications

**When Ordering Please Specify:**

1. Part Number of Lock.
  2. Part Number of Inside Handle, If Desired.\*
  3. Part Number of Outside Pull, If Desired.\*
  4. Part Number of Keeper, If Desired.\*
  5. Stile Thickness if Ordering Handle & Pull.
- \*See Handle, Pull, and Keeper Sheets.

## MORTISE LOCK

A high strength plate-mounted mortise lock built upon the 410 Series locks. Features excellent resistance to forced entry. Specially designed for pocket or flush mounting in wood doors. Also excellent for surface mounting in PVC and aluminum. May be used with W&F 120 series surface-mounted handles (see 120 series pages for details), thumbturns or keylock cylinders. Spring-loaded hook retracts on contact with jamb to prevent damage or accidental lockout when door is closed with hook extended. Compatible with a variety of keepers (see table below).

### Adjustability

Hook projection is adjustable to accommodate stile and jamb variations. Adjustment screw is conveniently located on lock face.

### Material

Case and mounting plate are cold-rolled steel. Precision molded hub is high strength thermal plastic. Laminated hook is heat-treated alloy steel.

### Feature Options

Diagonal hub for use with most 120 series handles; vertical hub for most other applications. Available in several fastener configurations. See reverse for part numbers.

### KEEPER USAGE

KEEPER \ LOCK	400-26-1	400-27-1	400-36-1	400-39-1	400-60-1	400-63-3	400-64-1
410-3	X	X	X	X	X	X	X
410-4	X	X	X	X	X	X	X
410-15	X	X	X	X	X	X	X
410-18	X	X	X	X	X	X	X
410-24	X	X	X	X	X	X	X
410-25	X	X	X	X	X	X	X
410-26	X	X	X	X	X	X	X
410-28				X			
410-29				X			
410-32				X			
410-34				X			
410-35				X			X
410-36				X			X

# 410 SERIES PLATE-MOUNTED MORTISE LOCK SPECIFICATIONS

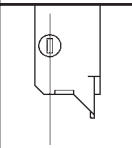
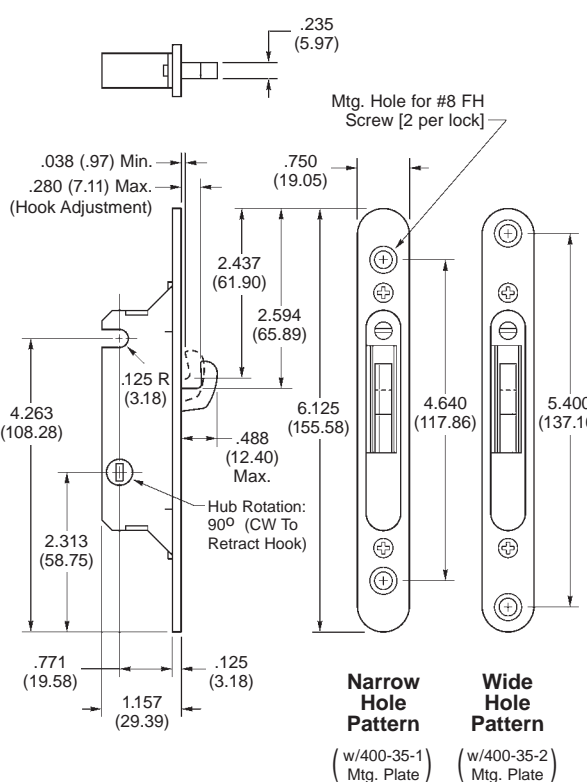
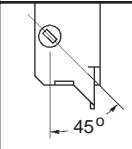
	410-18	410-24	410-25	410-26	Fastener Description
Part Number and Fasteners	410-18-0	410-24-0	410-25-0	410-26-0	No Screws
	410-18-900	410-24-900	410-25-900	410-26-900	(2) #8 x 1 1/4" FHSMS
	410-18-901	410-24-901	410-25-901	410-26-901	(2) 8-32 x 5/8" FHMS with 1 1/4" Binder Posts
 Vertical Hub (w/410-3-0 lock)			X	X	 <p>Technical drawing showing side and end views of the lock assembly with dimensions in inches and millimeters. Key dimensions include: .038 (.97) Min. / .280 (7.11) Max. (Hook Adjustment); .235 (5.97) for the hook; .750 (19.05) for the hook length; 2.437 (61.90) and 2.594 (65.89) for hole spacings; 4.263 (108.28) and 2.313 (58.75) for vertical dimensions; .125 R (3.18) for the hook radius; .488 (12.40) Max. for the hook width; 6.125 (155.58) and 4.640 (117.86) for hole spacings; 5.400 (137.16) for the total height; .771 (19.58) and .125 (3.18) for horizontal dimensions; 1.157 (29.39) for the hole offset; and .750 (19.05) for the hole diameter. Labels include 'Mtg. Hole for #8 FH Screw [2 per lock]', 'Hub Rotation: 90° (CW To Retract Hook)', 'Narrow Hole Pattern (w/400-35-1 Mtg. Plate)', and 'Wide Hole Pattern (w/400-35-2 Mtg. Plate)'.</p>
 Diagonal Hub (w/410-4-0 lock)	X	X			
Narrow Hole Pattern 4.640" (w/400-35-1 Mtg. Plate)	X			X	
Wide Hole Pattern 5.400" (w/400-35-2 Mtg. Plate)		X	X		

Note: Dimensions in (" ) Are in Millimeters.

## TYPICAL FABRICATION AND INSTALLATION

Contact W&F for Custom Layout on Your Product.

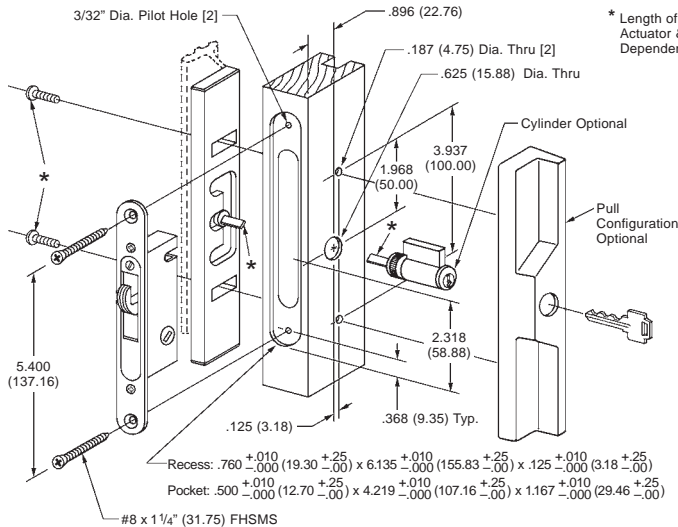

PAGEBOOK FABRICATION—FLUSH MOUNTING ON WOOD

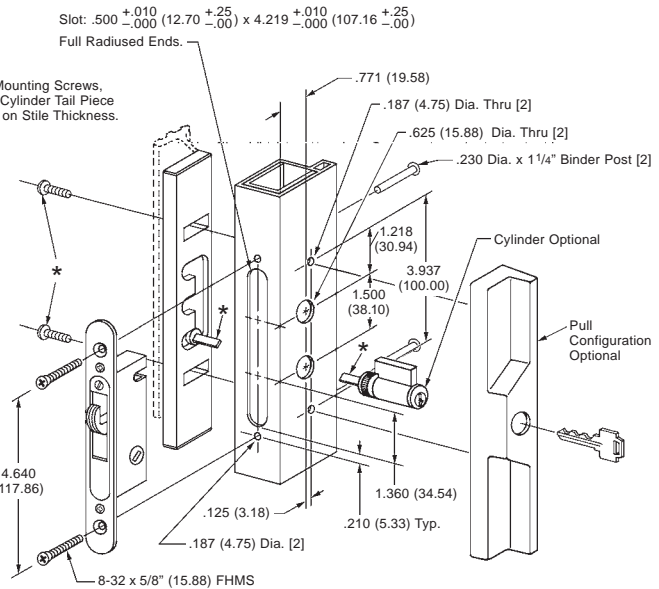

CARTWHEEL FABRICATION—SURFACE MOUNTING ON PVC

Copyright © 1996 Revised 7/98